

ED-23801-000
SHT 1.1

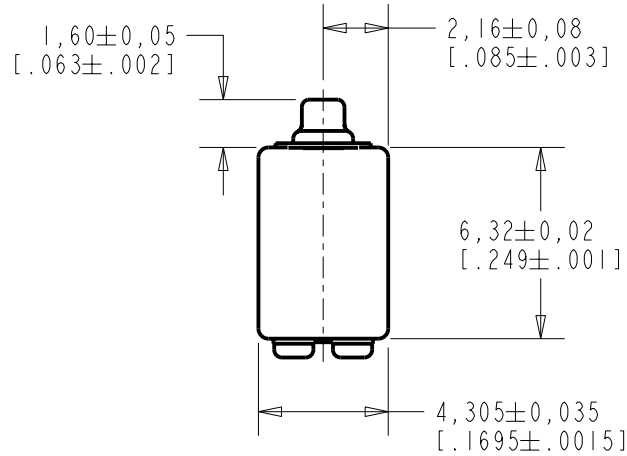

NOTE:

- 1 A POSITIVE GOING VOLTAGE AT TERMINAL 2, RELATIVE TO TERMINAL 1, CAUSES A DECREASE IN PRESSURE AT THE SOUND OUTLET.
- 2 LOCATED FROM TWO SURFACES FOR CUSTOMER CONVENIENCE. ONLY APPLICABLE FROM ONE SURFACE, NOT TO BE USED TOGETHER. HORIZONTAL LOCATION FOR TERMINAL CENTERED TO ±0,17 [.007].

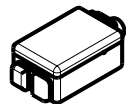
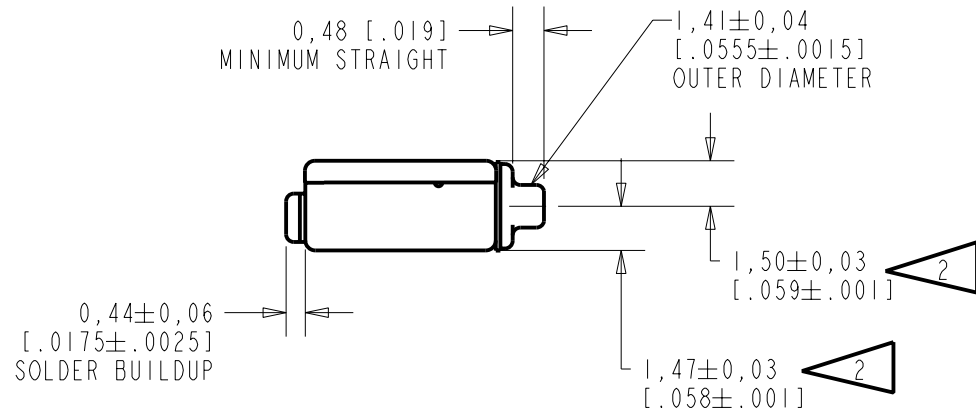
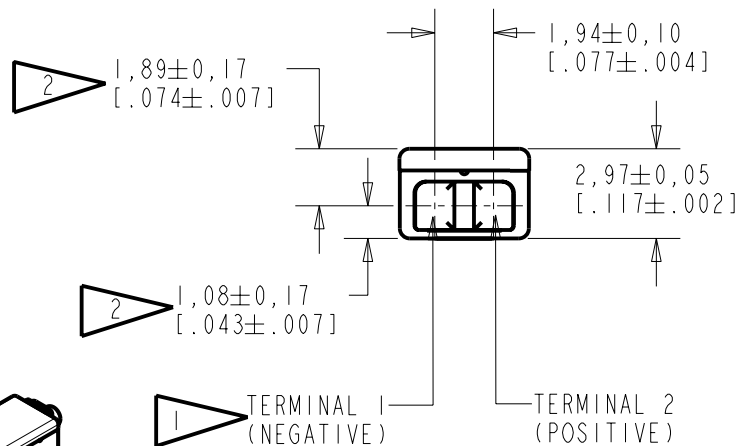

SCALE 2:1

NOMINAL WEIGHT
.31 GRAM

DIMENSIONS IN MILLIMETERS [INCHES]

KNOWLES ELECTRONICS
ITASCA, ILLINOIS U.S.A.

Revision	C.O. #	Implementation Date	RELEASE LEVEL	REVISION
			Released	A
A	CI0103511	12-29-05		
SCALE: 4:1				
TITLE: RECEIVER			DR. BY DATE	
OUTLINE DRAWING			CRG 12-29-05	
ED-23801-000			CK. BY DATE	
SHT 1.1			GJP 1-3-06	
			APP. BY DATE	
			GJP 1-3-06	

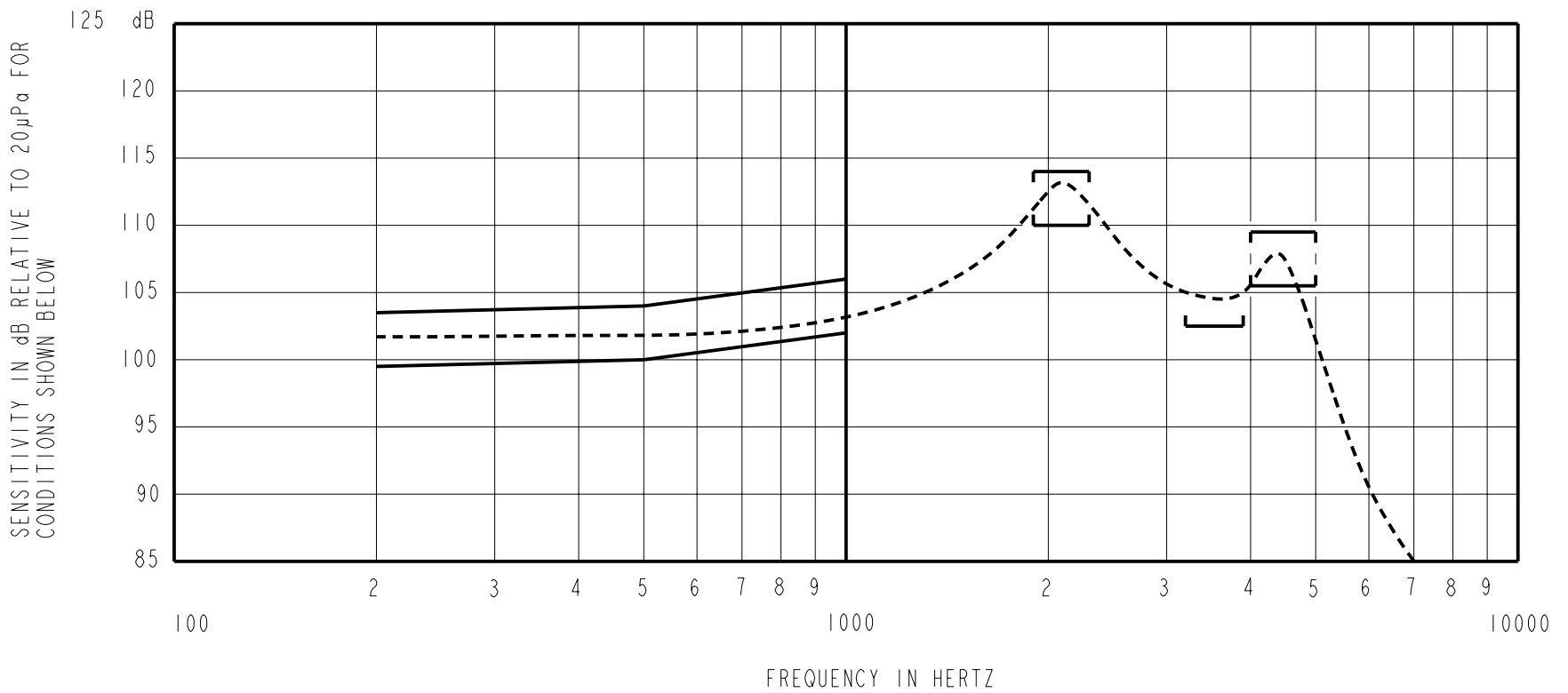

NOTES:

1. MEASUREMENTS MADE USING 10mm (.394") X 1mm (.039") ID TUBE CONNECTED TO A SIMULATED ANSI S3.7-1973 TYPE HA-3 COUPLER. (IEC 126).

2. SENSITIVITY

FREQUENCY	MIN.	MAX.
200	99.5	103.5
500	100.0	104.0
1000	102.0	106.0
1900-2300	110.0	114.0
3200-3900	102.5	---
4000-5000	105.5	109.5

- 3. RESPONSE, IMPEDANCE, AND DISTORTION MEASUREMENTS MADE USING THE ELECTRICAL TEST CONDITIONS SHOWN BELOW.
- 4. ELECTRICAL SOURCE IMPEDANCE MUST BE GREATER THAN 20 TIMES 1KHz IMPEDANCE FOR TEST CONDITIONS SHOWN BELOW.
- 5. INDIVIDUAL SPECIFICATIONS.

PORT LOCATION	IMPEDANCE OHMS ±15%		DCR @20°C OHMS ±10%	DISTORTION		ELECTRICAL TEST CONDITIONS	
	1KHz	500Hz		MAX. %	FREQ Hz	AC mA RMS	DC mA
12S	273	196	155	5	800	1.25	0.00

Revision	C.O. #	Implementation Date	RELEASE LEVEL	REVISION
			Released	A
A	C10103511	12-29-05		

KNOWLES ELECTRONICS
 ITASCA, ILLINOIS U.S.A.

WHEN TEST LIMITS ARE USED TO ESTABLISH INCOMING INSPECTION ACCEPTANCE/REJECTION CRITERIA, CORRELATION OF TEST EQUIPMENT WITH KNOWLES IS ALSO REQUIRED FOR ELIMINATION OF EQUIPMENT AND TEST METHOD VARIATION

TITLE: **RECEIVER**
 PERFORMANCE SPECIFICATION

ED-23801-000
 SHT 2.1

DR. BY	DATE
CRG	12-29-05
CK. BY	DATE
GJP	1-3-06
APP. BY	DATE
GJP	1-3-06